



ENDURA-FORM

MULTI PURPOSE CONSTRUCTION PANELS

INSTRUCTIONS

Assembling Endura-Form Multi-Purpose Panels is straight-forward but requires some careful thought and preparation beforehand and you should examine the panels carefully before you start to get an understanding of how the interlock system works. All Endura-Form panels are identical.

RECOMMENDED TOOLS: Cordless Hammer Drill (for tightening bolts), Tape Measure, Circular Saw for cutting panels). While Endura-Form panels can be assembled into a continuous interlocking surface of any size desired, these instructions show the proper assembly of a small deck - the principles apply to Endura-Form assemblies of any size. It is important to emphasize that the edges of any Endura-Form surface **MUST** be correctly aligned as shown in these instructions - failure to do so may result in serious damage to the panels as well as equipment and personnel. To do this correctly requires panels to be cut in a certain patterns so that when assembled, the edges are aligned correctly.

Please refer to the notes on the last page for more information on correct edge alignment.

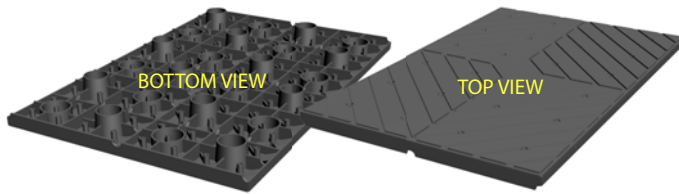

Figure 01: Showing the top and bottom views of a single Endura-Form panel. The bottom view shows the alternating pattern of interlocking structures that give the panel its ability to interlock. Panel size is 48" x 32"

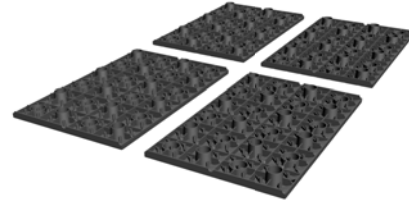

Figure 02: To begin assembling our sample Endura-Form surface, we start with laying out four panels with the interlocking parts facing up. All panels are oriented in the same direction.

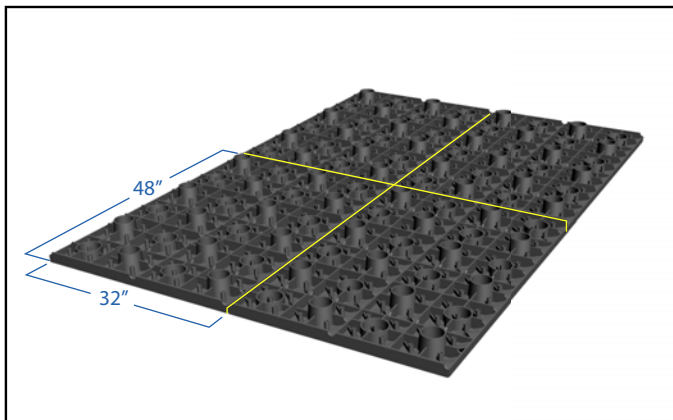

Figure 03: The four panels are placed edge to edge. Normally you should not need to cut any of the panels in the bottom layer.

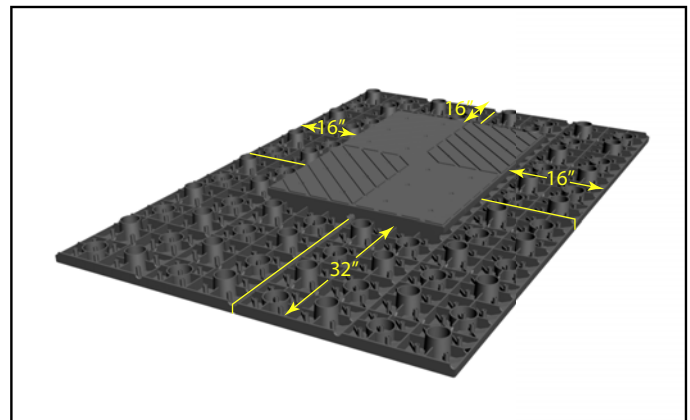

Figure 04: A panel is placed on top to interlock the four panels below. Make sure it is 16" from any final edge.

Panel Cut Patterns

To properly finish the edges of an Endura-Form surface requires panels cut to the correct sizes. If these are not supplied you must cut them yourself from regular Endura-Form panels.



Figure 10a : This cut pattern is used in figures 5 and 6 below to supply the finishing top pieces on the sides running along the short lengths of the main panels. The cut is 16" from one end, resulting in one piece 32" x 16" and another 32" x 32".



Figure 10b: This pattern is used in figures 7 and 8 below to supply the finishing top pieces on the sides running lengthways with the main panels. The panel is split lengthways down the middle leaving two equal 16" x 48" pieces.



Figure 10c: This pattern supplies the top outer edge pieces for the four corners of a rectangular surface as shown in figures 9 and 10. Two pieces are 16" x 16" and two pieces are 16" x 32".

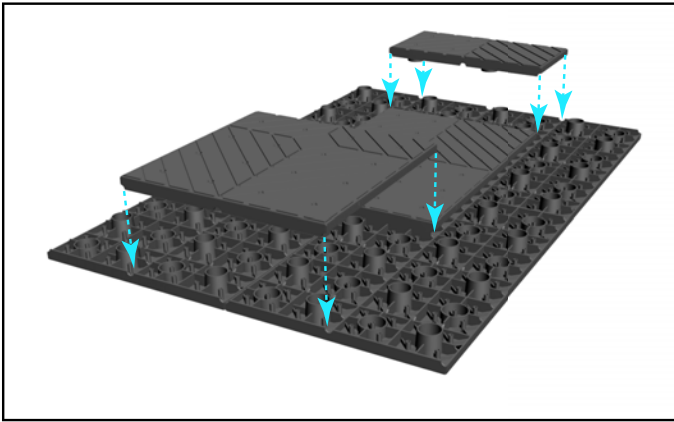

Figure 05: Cut a panel (or use pieces previously cut of the correct size and orientation) as shown in **figure 10a** and place the 32" by 16" piece so it finishes the edge on the far side of this view. The 32" x 32" would finish the opposite edge.

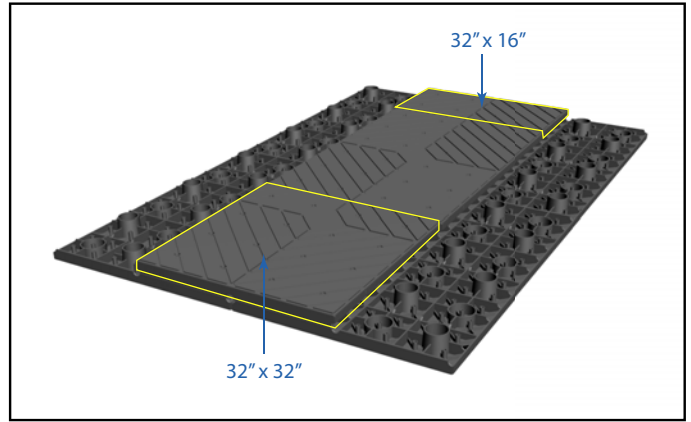

Figure 06: This shows the cut pieces in place as indicated by the outlines.

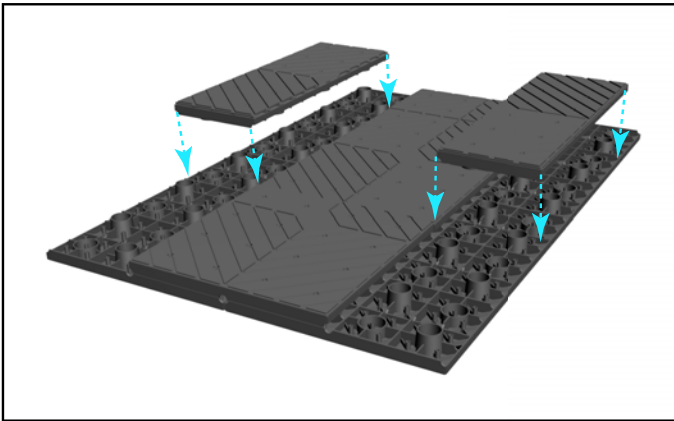

Figure 07: Cut a panel (or use pieces previously cut of the correct size and orientation) as shown in **figure 10b** and place the 16" by 48" pieces so they finish the edges on the "long" sides as shown in this view.

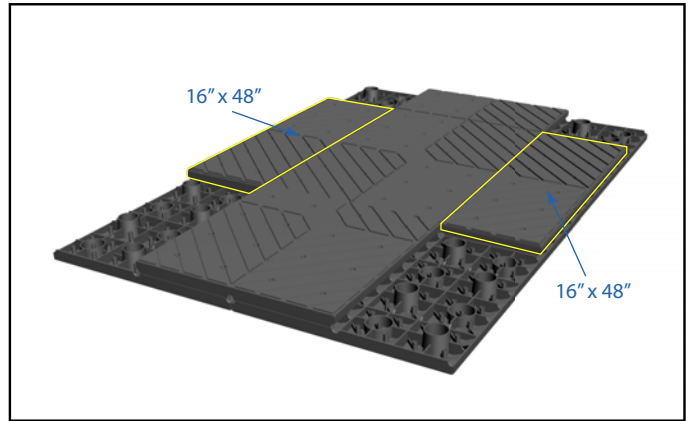

Figure 08: This shows the cut pieces in place as indicated by the outlines.

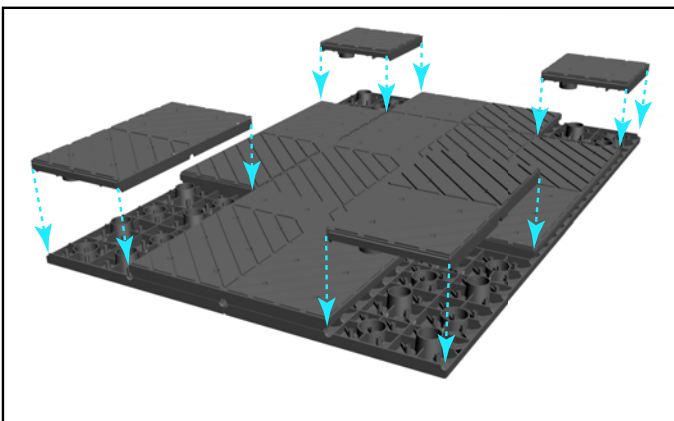

Figure 09: To finish laying out the example surface, cut a panel (or use pieces previously cut of the correct size and orientation) as shown in **figure 10c** and place the two 16" by 16" pieces so they fit the same sized spaces at the "short" end and use the 16" x 32" pieces to fill in the opposite corner spaces. This results in a properly aligned edge all the way around the surface (that is, the top and bottom panels line up evenly all the way around - this results in strong edges that will not break in normal use.

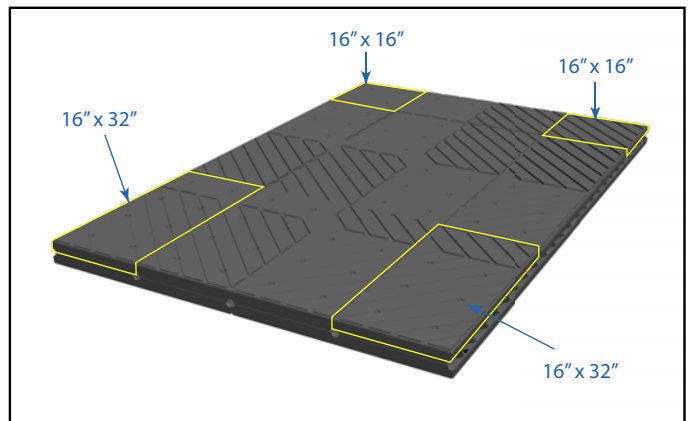

Figure 10: This shows the cut pieces in place as indicated by the outlines.
NOTE: if the panels are to have equipment driven over the edges, appropriate ramps must be used to prevent possible breakage at the edges. Likewise, steel tracked equipment should be used with planking or similar protection to prevent surface damage from excess abrasion.

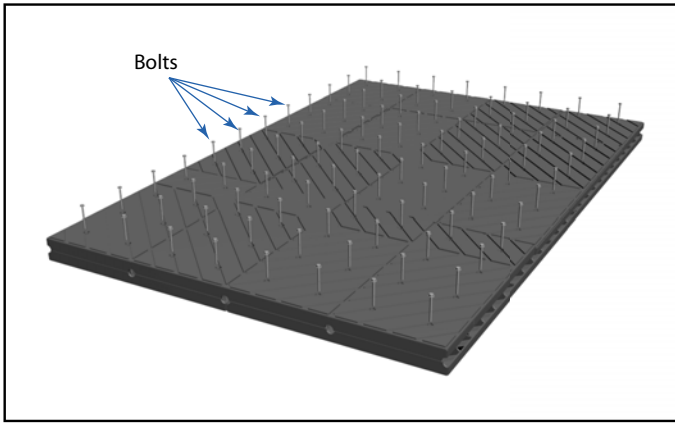

Figure 11: This illustrates the proper placement of the bolts and washers (and the opposite nuts and washers) to properly secure the Endura-Form surface - making it extremely strong. Endura-Form panels **MUST** be properly bolted before an installation is used. There are 24 bolts per panel.

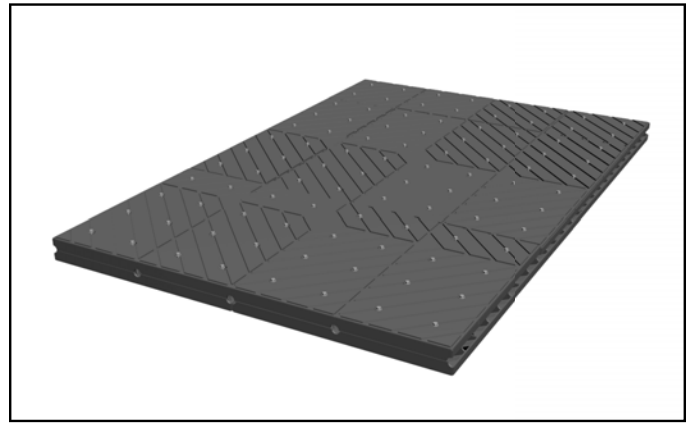

Figure 12: The finished Endura-Form surface ready for use. Keep in mind that the layout principles in this example are the same as would be used in any larger layout.



Figure 13: We highly recommend using a heavy duty cordless hammer drill and extension for tightening the bolts.



Figure 14: An example of a somewhat larger Endura-Form layout.



Figure 15: Photo of the example layout showing the spaces left after the correct positioning of the first top piece (as shown in figures 5 and 6).

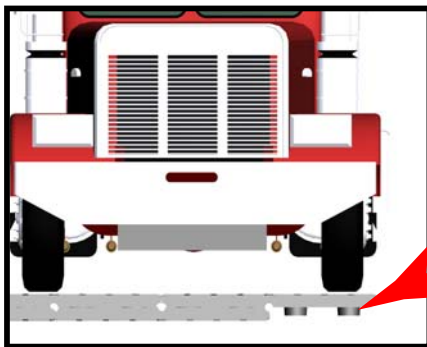

Figure 16: Photo of the example layout showing the last corner pieces slightly lifted to indicate their size and position (as shown in figures 9 and 10).

ATTENTION!

The Endura-Form panel is designed to be used with the top and bottom panels properly aligned all the way around the outer edge of any Endura-Form panel layout.

ANY OVERHANGING EDGES OR EXPOSED INTERLOCKING SURFACES MAY RESULT IN DAMAGE TO THE PANELS AS WELL AS BEING A POTENTIAL SAFETY HAZARD FOR PEOPLE AND EQUIPMENT USING THE INCORRECTLY INSTALLED PANEL LAYOUT.



OVERHANGING EDGE IS UNSAFE AND LIABLE TO BREAKAGE - DO NOT USE

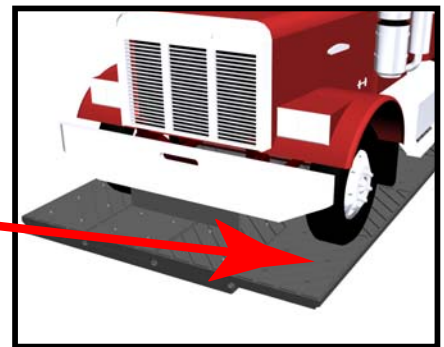

EXPOSED INTERLOCKING SURFACE IS UNSAFE & LIABLE TO BREAKAGE - DO NOT USE

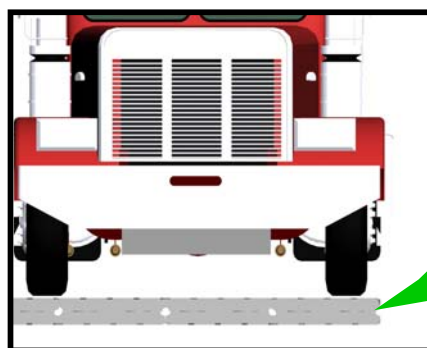
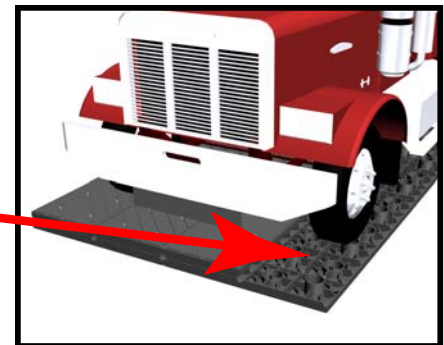

PROPERLY ALIGNED EDGE IS SAFE AND STRONG!

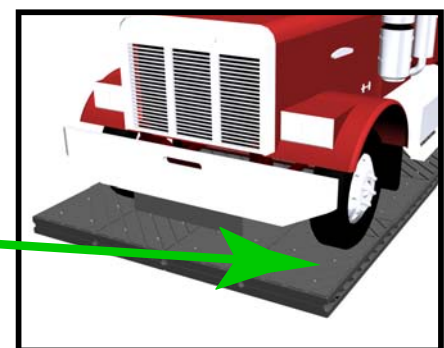

IMPORTANT! When properly installed, Endura-Form panels are rated for a maximum of **803 PSI**. **DO NOT EXCEED THIS LIMIT** or breakage may occur. If you suspect you may exceed the load limit (for instance, while using jack or similar lifting device) it is recommended to use a plate of metal or heavy plywood of the appropriate thickness and size to spread out the weight and achieve a PSI below the allowed limit. Minimum plate sizes of 20" to 24" square are recommended and of appropriate thickness according to the material used. Any warranty will be void if breakage occurs under these or similar circumstances if appropriate precautions are not taken.

EXAMPLES OF INCORRECT AND CORRECT WAYS TO SUPPORT HEAVY LOADS ON ENDURA-FORM PANEL FLOORS AND DECKS

INCORRECT

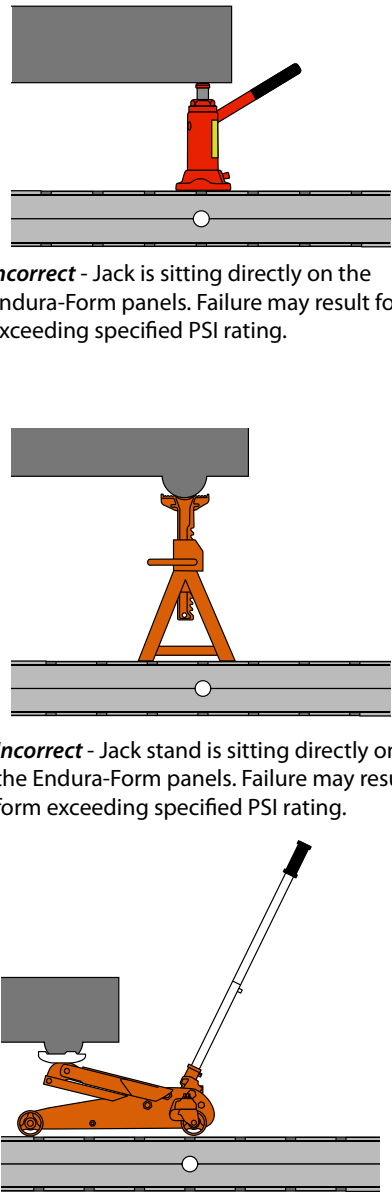

Incorrect - Jack is sitting directly on the Endura-Form panels. Failure may result form exceeding specified PSI rating.

Incorrect - Jack stand is sitting directly on the Endura-Form panels. Failure may result form exceeding specified PSI rating.

Incorrect - Floor jack is sitting directly on the Endura-Form panels. Failure may result form exceeding specified PSI rating.

CORRECT

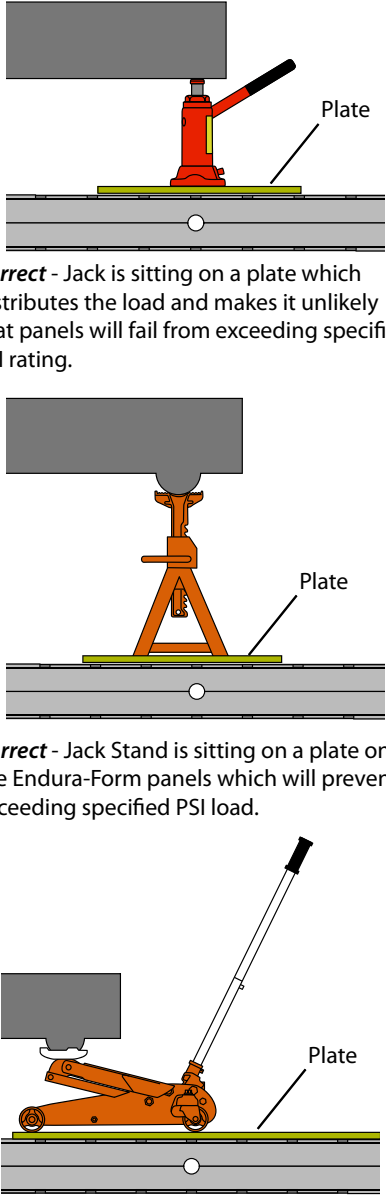

Correct - Jack is sitting on a plate which distributes the load and makes it unlikely that panels will fail from exceeding specified PSI rating.

Correct - Jack Stand is sitting on a plate on the Endura-Form panels which will prevent exceeding specified PSI load.

Correct - Floor jack is running on a plate on the Endura-Form panels which will prevent exceeding specified PSI load.

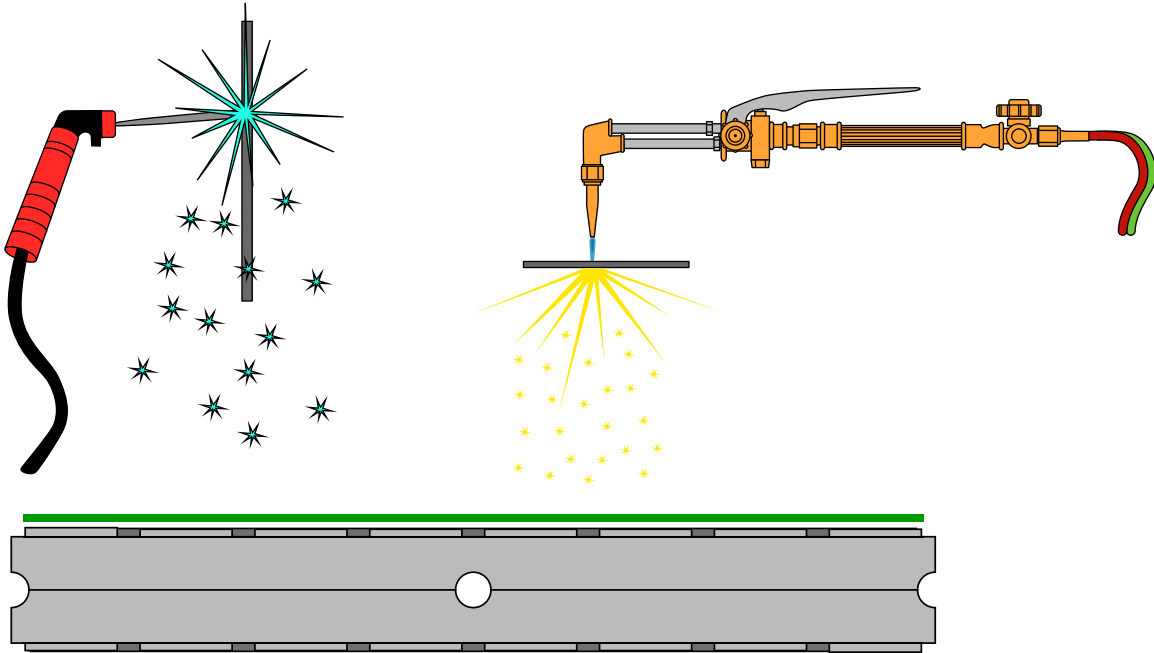

IF WELDING OR USING A CUTTING TORCH ON AN ENDURA-FORM FLOOR OR DECK PROPER PROTECTION MUST BE PROVIDED FOR THE PANELS - WELDING MATS OR OTHER APPROPRIATE COVERING MUST BE PROVIDED AS WELL AS WELDING CURTAINS WHERE SPARKS MAY TRAVEL BEYOND THE FLOOR PROTECTION.

SAFETY NOTE: Endura-Form panels have a slip-resistant surface and work well with most footwear. However, certain types of soles may present a potential safety issue. If there are concerns, please test before deploying the panels.

Warranty: Endura-Form Multi-Purpose Construction Panels are warranted for 12 months against breakage due to normal wear and tear or manufacturing defect. This warranty is limited to the products themselves. Endura-Form will provide no warranty of any sort to panels installed or used in an unapproved or unsafe manner. Engineering information on load levels etc. can be viewed online at [http://www.endura-form.com/bcit2/Endura-Form Computer Modelling-Summary.html](http://www.endura-form.com/bcit2/Endura-Form%20Computer%20Modelling-Summary.html). Endura-Form will accept no responsibility for any damages to property or person resulting from the use of our products. Use of this product is taken to mean you have carefully read and followed the proper installation instructions.

Please contact us if you have any questions about Endura-Form panels, their use and installation.

info@endura-form.com • 604-792-0232 • Fax: 604-792-1890

www.endura-form.com